

G2110B Push Lock

Features

- For metal framed glass doors or sheet metal double sliding doors
- **To Lock:**
 - Insert key and turn 60° clockwise
 - Push-in the cylinder with key and turn 60° back
- **To Unlock:**
 - Insert key and turn 60° clockwise and lock will automatically disengage
 - Turn the key 60° back and remove
- 12 key changes available
- Keys can be shared with **G2100 Lock Series**



Parts Included

- Countersunk head screw M3×5

Installation

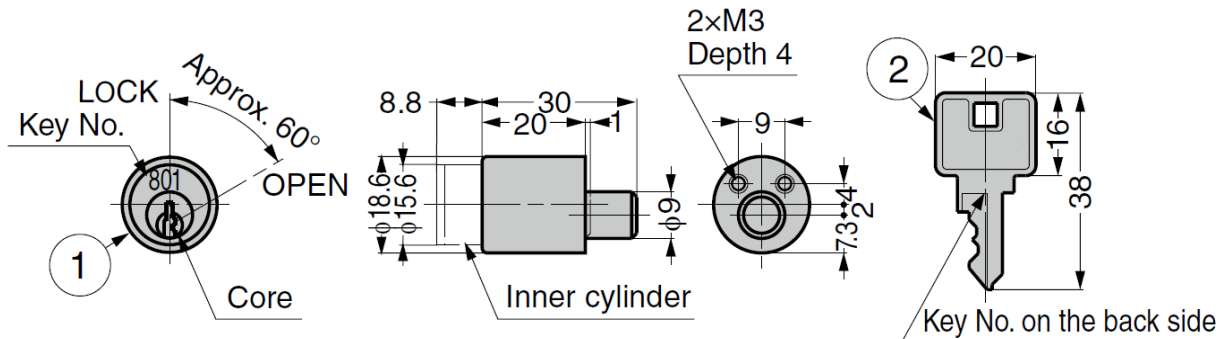
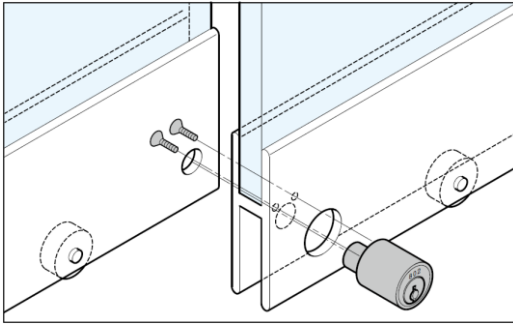

No.	Part Name	Material	Finish
①	Body	Zinc Alloy (ZDC)	Satin Nickel (Core: Buffing Nickel Coating)
②	Key	Brass	Nickel
-	Key Ring	Steel	

Part No.	Key Type	Cylinder Diameter	Thickness
G2110B-B	Keyed Differently	18.6	20
G2110B-D	Keyed Alike		